

# SG60

Escalier fixe en aluminium et garde-corps.

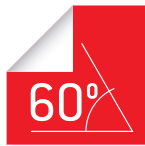

Marche antidérapante de 15 cm.

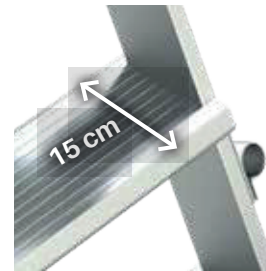

Rampe de débarquement de 110 cm.

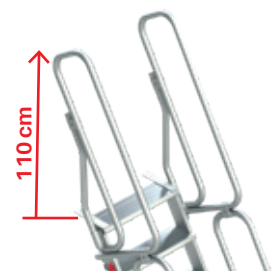

## CARACTÉRISTIQUES TECHNIQUES

ART.	NOMBRE DE MARCHES	Poids (Kg)	A. (cm)	B. (cm)	C. (cm)	G. (cm)
SG60-03	3	11	254	74	60	58
SG60-04	4	12	279	99	60	72
SG60-05	5	16	303	123	60	87
SG60-06	6	18	328	148	60	101
SG60-07	7	20	353	173	60	115
SG60-08	8	24	377	197	60	129
SG60-09	9	26	402	222	60	144
SG60-10	10	28	427	247	60	158
SG60-11	11	30	452	272	60	172
SG60-12	12	34	476	296	60	186
SG60-13	13	36	501	321	60	200
SG60-14	14	38	526	346	60	215
SG60-15	15	40	550	370	60	229
SG60-16	16	44	575	395	60	243

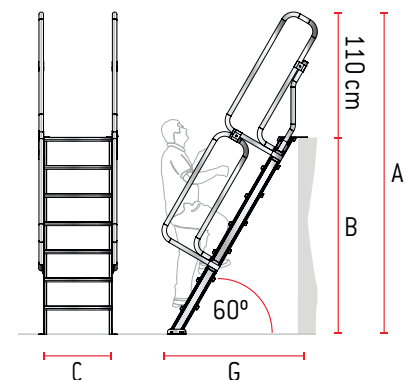

## ACCESSOIRES EN OPTION

ART.	DESCRIPCIÓN
SGE-PLA-60	Plate-forme de travail 60x100 cm.
S-CANCF60	Barrière de sécurité avant 60 cm.

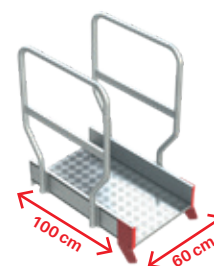

SGE-PLA-60



S-CANCF60